



## Cantinetta Frigo Incasso Sotto Top 20 Bottiglie - Singola Temperatura Built-in Under-Counter Wine Cooler for 20 Bottles - Single Temperature

\* Tipo Bordolese da 0,75 Lt. / \* Calculated with 0.75 Lt. Bordeaux bottles



- .Capacità: 20 Bottiglie\*
- .Compatibile con Vinotag\* 
- .Installazione: Libera / Incasso Sotto Top
- .Colore: Nero
- .Sistema di raffreddamento: Compressore
- .Refrigerazione: Ventilata
- .Temperatura regolabile: da 5° a 20°C
- .Regolazione elettronica
- .Termometro con display digitale
- .Illuminazione a LED con interruttore
- .Anta Reversibile in vetrocamera a triplo strato-UV

- .Capacity: 46 bottles\*
- .Compatible with Vinotag\* 
- .Installation: Freestanding / Under-counter
- .Color: Black
- .Cooling system: Compressor
- .Refrigeration: Ventilated
- .Adjustable temperature: from 5°C to 20°C
- .Electronic control
- .Thermometer with digital display
- .LED lighting with switch
- .Reversible triple-pane glass door with UV protection

### CARATTERISTICHE TECNICHE

- .Classe energetica: F
- .Consumo elettrico annuale: 98 kWh
- .Classe climatica: SN - ST
- .Rumorosità: 38 dB
- .Voltaggio: 220 - 240 V
- .Potenza assorbita: 200 W
- .Tipo di gas: R600a

### TECHNICAL SPECIFICATIONS

- .Energy class: F
- .Annual energy consumption: 98 kWh
- .Climate class: SN-ST
- .Noise level: 38 dB
- .Voltage: 220 - 240 V
- .Power consumption: 200 W
- .Refrigerant type: R600a

### ATTREZZATURE INCLUSE

- .5 ripiani in legno, scorrevoli
- .4 piedini regolabili (altezza 1,5 cm)
- .Filtro Carboni
- .Sistema Antivibrazione

### INCLUDED ACCESSORIES

- .5 wooden sliding shelves
- .4 adjustable feet (height 1,5 cm)
- .Charcoal Filter
- .Anti-vibration system

### VINOTAG®

- .Applicazione gratuita per la gestione della tua cantina

### VINOTAG®

- .Free management application of your cellar



Dimensioni/Dimensions  
Larghezza/Length: 29,5 cm  
Profondità/Depth: 57,0 cm  
Altezza/Height: 82,0 cm  
Peso/Weight: 29 kg

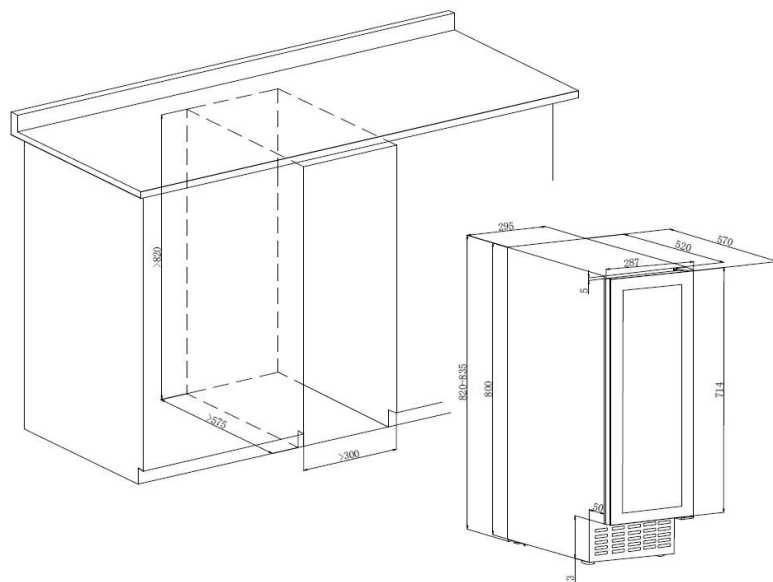

Temperatura d'Esercizio: da 10° a 38°C - Ambient temperature: from 10° a 38°C